

Linear unit with direct drive

iLD 10

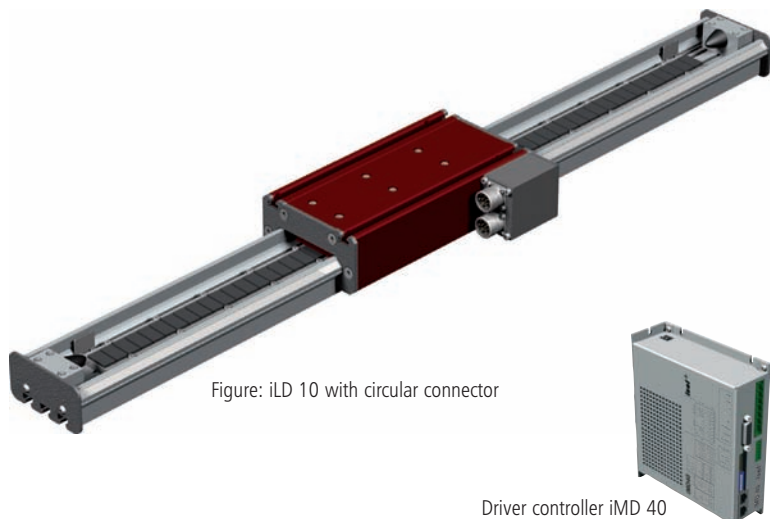

Figure: iLD 10 with circular connector

Driver controller iMD 40

Characteristics

- Aluminium linear guide with magnetic track and drive slide with spool pack
- No signal dead range, elimination of mechanical transmission elements
- Higher performance on a smaller scale
- String potentiometer 10 μm
- Guide is stable and twist-proof
- Widely separated guide surfaces of swallowtail shaped strip steel
- Cleanroom-compatible version
- Quiet operation, adjustable backlash-free
- High dynamics with movement speeds of up to 6.0 m/s
- No maintenance or lubrication required
- Profile lengths to 6m

Optional:

- Drive control
- Bellows cover
- String potentiometer 5 μm
- Circular connector

General

The iLD 10 linear units with direct drives are for tasks and applications in the handling area with a favourable price/ performance ratio. The base is comprised of aluminium profiles with swallowtail design shaped steel guides and internal magnetic tracks with a string potentiometer. Inside the drive slides are at least 4 ball bearings, adjusted backlash-free, as well as the spool pack with path measuring head. This results in a quiet operation without signal dead range, with high dynamics and movement speed.

Technical specifications

	iLD 10-6	iLD 10-12
Weight profile (incl.end plates) [kg/1000mm]	8.80	8.80
Weight slides [kg]	4.40	6.30

Acceptable static load

Force in Z direction [N]	1,202	702
Force in Y direction [N]	1,202	702
Momentum around X-axis [Nm]	64	64
Momentum around Y-axis [Nm]	138	138
Momentum around Z-axis [Nm]	138	138

Acceptable dynamic load

Force in Z direction [N]	2,972	2,472
Force in Y direction [N]	2,972	2,472
Momentum around X-axis [Nm]	131	131
Momentum around Y-axis [Nm]	282	282
Momentum around Z-axis [Nm]	282	282
Max. feed force [N]	170	340
Max. nominal speed [m/s]	6.0	6.0

Order data

Drive slide AS 10-6
with spool pack and hall PCB
W/H/L 130x65x255 mm
Item no.: 486020 0002

Drive slide AS 10-12
with spool pack and hall PCB
W/H/L 130x65x410 mm
Item no.: 486020 0004

Linear guide MF 10
with magnetic track MS 25
W/H/L 100x52x1000 mm
Item no.: 486120 1000

Linear guide MF 10
with magnetic track MS 25
W/H/L 100x52x2000 mm
Item no.: 486120 2000

Linear guide MF 10
with magnetic track MS 25
W/H/L 100x52x3000 mm
Item no.: 486120 3000

Subject to technical alterations.