

Accurate

TECHNOLOGY INC.

Linear Digital Measuring Systems

Data Multiplexers & Converters



User Manual for:

**ProMUX-3, ProMUX-8 &
D/A Converter**

Warranty

Accurate Technology, Inc., this product against defective parts and workmanship for 2 years commencing from the date of original purchase. Upon notification of a defect, Accurate Technology, Inc., shall have the option to repair or replace any defective part. Such services shall be the customer's sole and exclusive remedy. Expenses incidental to repair, maintenance, or replacement under warranty, including those for labor and material, shall be borne by Accurate Technology, Inc. (Including freight or transportation charges during the first 30 days).

Except as expressly provided in this warranty, Accurate Technology, Inc., does not make any warranties with respect to the product, either expressed or implied, including implied warranties of merchantability or fitness for a particular purpose, except as expressly provided in this agreement.

Accurate Technology, Inc., shall not be liable for any special, incidental, or consequential damages or for loss, damage or expense directly or indirectly arising from the customer's use of or inability to use the equipment either separately or in combination with other equipment, or for personal injury or loss or destruction of other property, or from any other cause.

To request repair work (either warranty qualified parts or not), contact Accurate Technology, Inc. directly by phone, fax, or e-mail. A **Returned Merchandise Authorization (RMA)** number is required before returning a product for repair.

Accurate Technology, Inc.

+1 828.654.7920 800.233.0580 828.654.8824 (F)

www.proscale.com

info@accurate-technology.com

SAFETY WARNING

**Before installing ProScale on any machinery:
Turn off the machine and disconnect the power.**

SAFETY WARNING

Table of Contents

SECTION 1	GENERAL INFORMATION	5
INTRODUCTION		5
ProMUX-3		5
ProMUX-8		5
Analog interface Unit (AIU)		5
WHAT THIS MANUAL INCLUDES:		5
PRODUCT SPECIFICATIONS		6
ProMUX-3		6
ProMUX-8		6
Analog Interface Unit		6
SECTION 2	PROMUX-3	7
CONNECTIONS		7
Encoder Connections		7
Power and Serial Port Connections		7
COMMUNICATING WITH THE PROMUX-3		8
Command Structure		8
Command List		8
Position Request Command		9
Encoder Enable		10
Multi Segment Mode		11
Adjust Segment Offset		11
Streaming Position Output		12
Firmware Version		12
Command Timing		13
Baud Rate Setting		13
Non-Volatile Memory		13
Factory Default Settings		13
ENCODER CONNECTOR INTERFACE		14
DB9 CONNECTOR PIN-OUT		14
SECTION 3	PROMUX- 8	15
GENERAL DESCRIPTION		15
FEATURE LIST		16
TYPICAL RS232 PROMUX-8 INSTALLATION		17
TYPICAL RS422 PROMUX-8 INSTALLATION		18
COMMUNICATIONS FORMAT		19
DATA FORMAT		19
POSITION REPRESENTATION		20
ASCII STRING POSITION FORMAT		20
BINARY POSITION FORMAT		21
MODULE COMMANDS		22
Position Command (P)		22
Scale Segment Adjustment Command (S)		23
Multi-Segment Mode Command (L)		24
Enable Active Encoders Command (M)		25
Encoder Types Command (E)		26
Inter-Command Delay (I)		27

Position Transmit Mode Command (F)	28
Checksum Operation Command (C).....	29
COMMAND TRANSMISSION NOTES.....	30
JUMPER SETTINGS.....	30
SERIAL INTERFACE PHYSICAL LAYER SETTING.....	30
BAUD RATE SETTING	30
LUCAS ACCUSTAR SUPPORT	31
SELF-TEST	31
ADDRESS SETTING	31
DEFAULTING TO FACTORY SETTINGS.....	31
NETWORK CONNECTIONS	32
RS-232 Connections	32
RS-422 Connections	32
POWER PANEL CONNECTIONS.....	33
ENCODER PANEL CONNECTIONS	33
SECTION 4 ANALOG INTERFACE.....	34
GENERAL DESCRIPTION.....	34
Basic Theory of Operation.....	34
TERMINAL BLOCK CONNECTIONS.....	35
MOUNTING	35
CONNECTIONS	35
CALIBRATION AND POSITION LIMIT SETTING	36
DETERMINING THE VOLTAGE PER STEP OUTPUT.....	36
CONSIDERATIONS IN A/D CONVERSIONS.....	37
PROGRAMMABLE OUTPUT.....	37
RE-ESTABLISHING FACTORY DEFAULTS.....	38
FACTORY DEFAULT VALUES.....	38
POWERING THE PROSCALE.....	38
PRODUCT REGISTRATION	39

Introduction

ProMUX-3

The ProMux 3 is an easy to use hardware interface device providing communication and control of one to three ProScale ABS linear encoders from a user provided PC or PLC via an RS232 serial interface.

Uses for the ProMux 3 include axis position measurement on XY or XYZ quality control measurement tables, machinery position control (**NON-CNC**), tooling measurement devices and the like.

ProMUX-8

ProMUX-8 linear encoder multiplexers are designed for OEM and system integrators for use in acquiring setup positional information (non-CNC) on industrial production machinery.

The multiplexers interface directly with Accurate Technology's ProScale™ line of absolute linear measurement encoders. These encoders provide linear measurement ranges from 100mm to 6 meters depending on the model. In addition, the ProMUX-8 multiplexers also support Accustar™ vertical angle measurement sensors from Lucas® Control Systems.

ProMUX-8 multiplexers communicate with a host PC or PLC via RS-232 or RS-422 serial interface. Various baud rates are supported from 9600 to 115200. Up to 15 multiplexers can be connected to the same communications bus when utilizing the RS-422 serial interface.

Analog interface Unit (AIU)

The Analog Interface Unit or AIU is an interface device that provides the user of a ProScale digital measurement system with a method of generating an analog DC output voltage that is proportional to the currently displayed ProScale measurement system position. This output can be used as an A/D converter input on a PLC or other device that utilizes an analog input signal.

What This Manual Includes:

- **ProMUX-3** 3 input – RS232 Data Multiplexer
- **ProMUX-8** 8 input – RS232/RS422 Data Multiplexer
- **AIU** Digital – Analog converter

Product Specifications

ProMUX-3

Dimensions:	2.6" x 4.25" x 1.125"
(W x L x H)	[66mm x 108mm x 29mm]
Power:	8.5 to 24 VDC (12 VDC power supply provided.) P-5 power connector
Encoder Inputs:	3 ProScale ABS readheads or SPC displays.
Serial Interface:	RS-232, DB-9 connector. 8 bit word, no parity, 1 stop bit No flow control.
Baud Rates:	9600, 19200 jumper programmed (19200 is default)
Memory:	EEPROM non-volatile memory.
Encoder Status:	LED indicators and status word.
Protection:	Reverse polarity protection. Two stage over voltage protection. Transient voltage protection on all inputs.
Encoder Sampling:	Approximately 10 samples/second.
Streaming Data Rate:	Approximately one transmission every 100 milliseconds.

ProMUX-8

Dimensions:	5.1" x 4.1" x 1.8"
(W x L x H)	[130mm x 105mm x 45mm]
Power:	14 to 24 VDC
Encoder Inputs:	8 ProScale ABS readheads.
Serial Interface:	RS-232, RS422
Baud Rates:	9600, 19200, 57600, 115200
Memory:	EEPROM non-volatile memory.
Encoder Status:	LED indicators and status word.
Protection:	Transient voltage protection on all inputs.
Encoder Sampling:	Approximately 8 channels/100ms.

Analog Interface Unit

Power:	7 – 24 VDC
Analog output	0-5 or 0-10 VDC
Mounting	DIN rail, 35 mm wide
Memory	Non-volatile EEPROM

Connections

Encoder Connections

The ProMUX-3 is supplied as two separate components. First is the ProMUX-3 interface unit and second is a low voltage plug-in power supply. The user must provide the host PC or PLC and a standard DB-9 serial cable (male to female).

Install the ProScale readhead and linear scale on the machine, then plug in the modular connector from the ProScale readhead (or display output) to the ProMUX-3 multiplexer. The corresponding LED will be illuminated when a ProScale readhead (or display output) signal is detected. (ProMUX-3 is factory configured to identify encoders connected to input 1. Other inputs must be enabled through programming. See page 10 for more information.) The diagram below illustrates the encoder connection ports of the multiplexer and the port assignments.

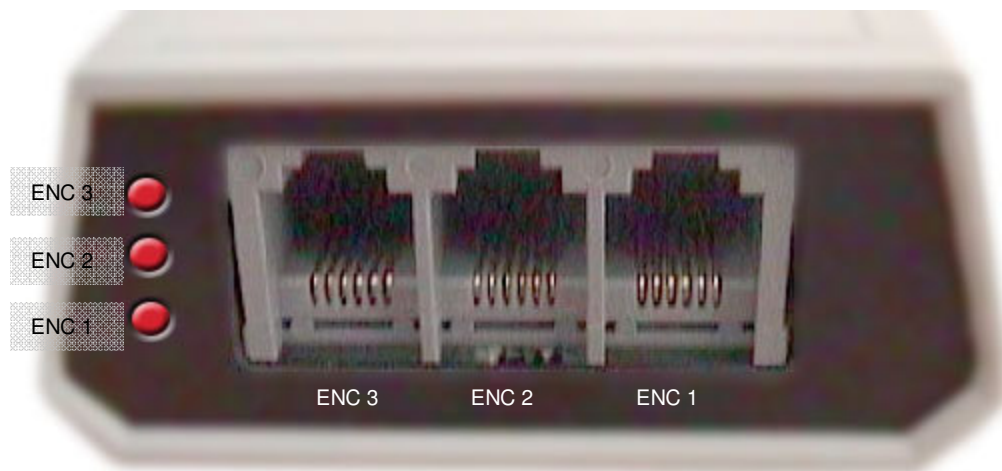

Power and Serial Port Connections

Connect your serial cable to the communications port of the ProMUX-3. Then connect the cable to the host computer. **NOTE: MAXIMUM CABLE LENGTH IS 25 FEET (8 meters).**

The ProMUX-3 is provided with a plug-in power supply that will power both the multiplexer and any ProScale readheads that are directly connected. Plug the power connector into the mating jack on the ProMUX-3 multiplexer. Then connect to a standard wall receptacle.

Communicating With the ProMUX-3

Command Structure

All commands sent to and received from the multiplexer are in standard ASCII format. This allows the user to initially test the communications channel with the ProMUX-3 utilizing a terminal emulation program such as HyperTerminal®. All commands sent to the multiplexer are based on the following format:

1. Command character (i.e. P for position command)
2. Optional parameter 1
3. Optional parameter 2
Command Terminator character (semicolon ;) OR <ENTER> (Decimal 13 or 0Dh)

The ProMUX-3 will respond with the appropriate data. This can be any of the following:

1. Position Data
2. Command Acknowledgment (OK)
3. Command Failure (?)

The first character of all responses will always be the asterisk *. This provides a sentinel character to synchronize the response with the host if needed. Following the asterisk, one of the above responses will be sent. A carriage return character (0Dh) ends the message stream.

Command List

The following is a list of commands that may be sent to the ProMUX-3. If an invalid command is sent, the multiplexer will respond with a Command Failure (?).

Action	Command	For More Information
Position Request	P; or p;	See page 9
Encoder Enable	M<control character>	See page 10
Multi-Segment Mode	L<control character>	See page 11
Adjust Segment Offset	S<channel><+ or ->	See page 11
Streaming Output	A<control character>	See page 12
Firmware Version	V;	See page 12

Position Request Command

This command is used to acquire the current position data from the ProMUX-3 multiplexer. The response includes the position information for all encoders (including a status character which indicates the operating condition of each encoder).

Command: P; or p;

Response: *s-xxxx.xx-yyyy.yy-zzzz.zzL<CR> where:

* = Sentinel Character (see page 8)

s = Status Character (See table below)

-xxxx.xx = Position of encoder 1

-yyyy.yy = Position of encoder 2

-zzzz.zz = Position of encoder 3

L = Data input latch

<CR> = Carriage Return

Status Character: The following table defines values of the status character. (The multiplexer uses a bitwise operation to map the state of each encoder. If the bit is set, the encoder is connected and operating properly. If the bit is clear, the encoder has failed or is not connected.)

Status Character	Enc1	Enc2	Enc3
1	OK	FAIL	FAIL
2	FAIL	OK	FAIL
3	OK	OK	FAIL
4	FAIL	FAIL	OK
5	OK	FAIL	OK
6	FAIL	OK	OK
7	OK	OK	OK

Position of Encoder: The encoder position can be in either millimeters or inches. Readheads which are connected directly to ProMUX-3 ALWAYS transmit in millimeter format. ProScale displays transmit in the currently displayed units.

Millimeter format is: -xxxx.xx (default) or -xxxxx.x

Inch format is: -xxxx.xx, -xxx.xxx (default), or -xx.xxxx

The minus sign position in each parameter will appear as:
minus ‘-’ sign if the position value is negative OR
a space if the position is positive.

Data input latch: A data field with a valid range from ASCII 0 to ASCII 7 (0x30 – 0x37). It represents a bit field used to indicate if a hardware input has been triggered which signifies to the host to latch the current position data for that encoder channel. This can be used to support a “Data Read” function indicating to the host when significant position data is available. See appendix A for hardware connection information.

Encoder Enable

This command tells the ProMUX-3 multiplexer which inputs to read. The ProMUX-3 is factory set to enable only encoder 1. A control character is sent to indicate which encoders are to be made active. Use the table below to choose the appropriate control character.

Command: M<control character 1-7>;

Response: *OK<CR> Command accepted. OR
*?<CR> Command rejected.

Example: Command **M5**; issued.
Response is *OK<CR>
ProMux 3 is now enabled for inputs on 1 and 3.

Control Character	Enc1	Enc2	Enc3
1	ENABLE	DISABLE	DISABLE
2	DISABLE	ENABLE	DISABLE
3	ENABLE	ENABLE	DISABLE
4	DISABLE	DISABLE	ENABLE
5	ENABLE	DISABLE	ENABLE
6	DISABLE	ENABLE	ENABLE
7	ENABLE	ENABLE	ENABLE

Multi Segment Mode

Accurate Technology ABS ProScale linear measurement systems are designed utilizing a printed circuit board material (scale panel) laminated to an aluminum extrusion. The length of this scale panel is approximately 430 millimeters (16.9 inches). Measurement scales longer than 430 millimeters require the installation of multiple scale panels end to end to provide the additional measurement range. The ProMUX-3 automatically accounts for transitions from one scale panel to another and provides a continuous linear position update to the host. When using a ProScale SPC display directly with the multiplexer, this feature must be disabled for that encoder channel. This must occur because the ProScale ABS display already accommodates the multiple scale panel operation. Use the table on page 9 to choose the appropriate value for the control character.

Command: L<control character>;
Response : *OK<CR> Command accepted. OR
*?<CR> Command rejected.

Example: Command **L4**; is issued.
Response is *OK<CR>
ProMUX-3 is now enabled for multi segment mode for ONLY encoder channel 3.

Adjust Segment Offset

As described in the previous section, the ProMUX-3 automatically compensates for scale panel transition. However, in cases where power is removed from the multiplexer, then the encoder readhead is moved from one scale panel to another, then power is restored to the multiplexer, the system will report an improper position for that encoder. To compensate for this condition, the host computer can send a command to the multiplexer to add or subtract one scale panel length (430 mm), resulting in an adjusted encoder position being reported. This command can be issued multiple times to compensate for multiple panel errors.

Command: S<encoder channel 1, 2 or 3><+ or ->;
Response: *OK<CR> Command accepted. OR
*?<CR> Command rejected. Invalid parameter.

Examples: Command **S2+**; issued. Response is *OK<CR>
ProMUX-3 adds 430 mm to the current position of encoder 2.
Command **S1-**; issued. Response is *OK<CR>
ProMUX-3 subtracts 430 mm to the current position of encoder 1.

Streaming Position Output

This command enables or disables streaming position output to the host. If enabled, position output is sent from the multiplexer to the host without the Position Command being received. If disabled, the host must use the Position Command to receive the encoder position data.

Command: A<0 for disable, 1 for enable>;
Response: *OK<CR> Command accepted. OR
*?<CR> Command rejected.

Example: Command **A1**; issued. Response is *OK<CR>
ProMUX-3 is now enabled for streaming position output.

Firmware Version

This command is used to query the ProMUX-3 for its firmware revision level.

Command: V;
Response: *n.nn<CR>

Example: Command **V**; issued. Response is *1.06<CR>
Firmware Version is 1.06.

Command Timing

The ProMUX-3 expects a maximum delay of 10 seconds between characters when sending a command. If the 10 second limit is exceeded between characters, the pending command is aborted and must be re-sent from the beginning.

Upon receiving a valid command from the host, the ProMUX-3 will send a response within approximately 1 millisecond.

Baud Rate Setting

To modify the baud rate setting:

1. Remove power from the unit.
2. Remove the four screws from the bottom of the unit.
3. Remove the top cover from the multiplexer.
4. A single two-position jumper exists located behind the DB-9 serial port connector. For 9600 baud, move the jumper to the two pins closest to the “9600” marking on the PC board. For 19200 baud, move the jumper to the two pins closest to the “19200” marking.
5. Re-assemble the housing and install the four screws.

Non-Volatile Memory

The ProMUX-3 utilizes an EEPROM memory system that retains vital system parameters after power has been disconnected. These parameters include:

- Scale Panel Offsets
- Encoder enable/disable settings
- Multi-segment operation mode settings
- Host transmit mode settings

Because of the non-volatile memory, configuration commands that are sent to the multiplexer are retained between applications of power and do not need to be reset after each power-up sequence.

Factory Default Settings

The ProMUX-3 is factory set to the following parameters:

Baud Rate 19200.
Encoder channel 1 enabled.
Multi-segment Mode enabled on all channels.
Streaming Position Output is disabled.

Encoder Connector Interface

This diagram is the encoder connection between ProMUX-3 and ProScale readheads.

6 Pin Modular Connector on ProMUX-3 (Socket)

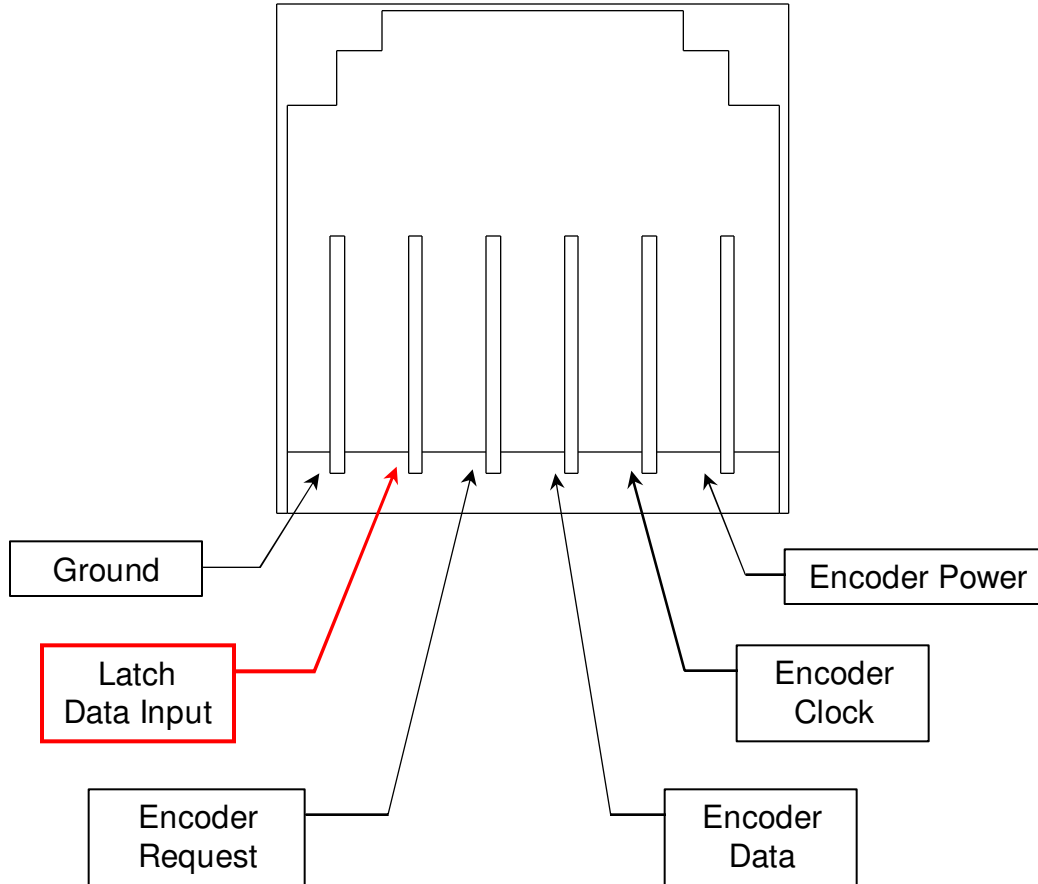

The Latch Data Input pin can be used to indicate to the host when significant position data is available for each encoder. To activate this input, momentarily connect this pin to Ground via a normally open switch. When activated, the corresponding bit in the Latch Data field of the position command will be set. Typically, this input must be held at ground for at least 50ms to be detected by the host.

WARNING: Do not connect positive voltage to this pin. Only connect GROUND. Positive voltages in excess of 5 VDC will cause damage to the ProMUX-3.

DB9 Connector Pin-out

Pin 2 – RS-232 Transmit to Host
Pin 3 – RS-232 Receive from Host
Pin 5 – Signal Ground

Note: Hardware handshaking is not supported.

General Description

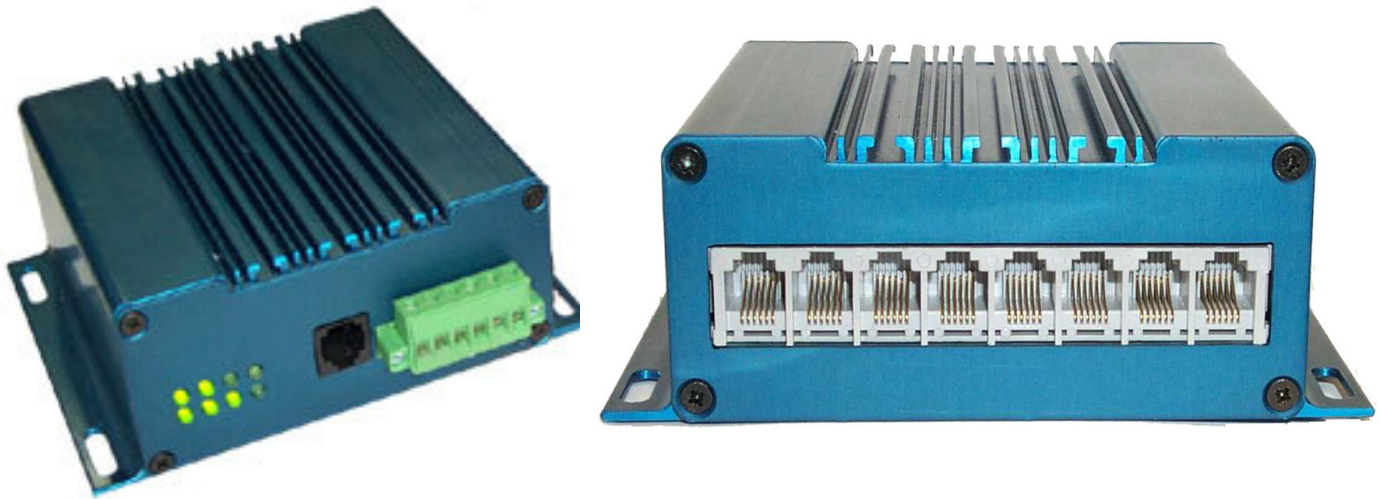

The ProMUX-8 allows up to 8 ProScale ABS readheads to be directly connected to the unit. The module supports ProScale encoder measurement ranges from 100mm to 6 meters.

The multiplexer continuously monitors the position of each axis, formatting the positional data into standard ASCII strings or floating point binary data. When a position request command is received from the host, the ProMUX-8 will respond with the status and positional information for ALL ProScale encoders. Status information indicates the presence of a ProScale encoder in each module channel plus the current status of the power supply output to the ProScale encoders. If a short-circuit occurs on an encoder cable, the ProMUX-8 will report an encoder power supply failure.

When configured for RS-232 mode, each ProMUX-8 module must utilize an individual RS-232 serial port on the host. In the RS-422 mode, up to 15 ProMUX-8 modules can be attached to a common 4-wire connection to provide overall system communication. In both configurations, the ProMUX-8 can be configured to one of four baud rates (9600, 19200, 57600, 115200) and provides user programming of module ID number via rotary switch setting.

The ProMUX-8 module provides positional information based on the absolute reference data from the ProScale encoder. Artificial origin or other position-offset information must be generated and retained by the host in non-volatile memory between power cycles.

Feature List

The principle features of the ProMUX-8 multiplexer include:

- 14 – 24 VDC power supply operation.
- RS-232 or RS-422 serial interface with multiple baud rates.
- Supports up to 8 ProScale™ linear measurement encoders.
- Supports Accustar™ vertical angle measurement sensors.
- Provides position update of all eight channels every 100 milliseconds.
- Built-in transient voltage protection.
- Internal diagnostics monitor sensor supply voltages.
- Integral LED encoder status indicators.
- Robust aluminum mounting enclosure: 130mm W x 105mm D x 45mm H.
- EEPROM non-volatile memory for storage of parameters and configuration.
- Positional data preformatted into ASCII strings.
- Software indication of encoder status (OK or failure).
- Programmable binary position transfer mode.
- Programmable data packet checksum operation.

Typical RS232 ProMUX-8 Installation

This diagram illustrates a single ProMUX-8 module utilizing RS232 communications. (For clarity: ProMUX-8 shown with 4 inputs and power connections on same panel.)

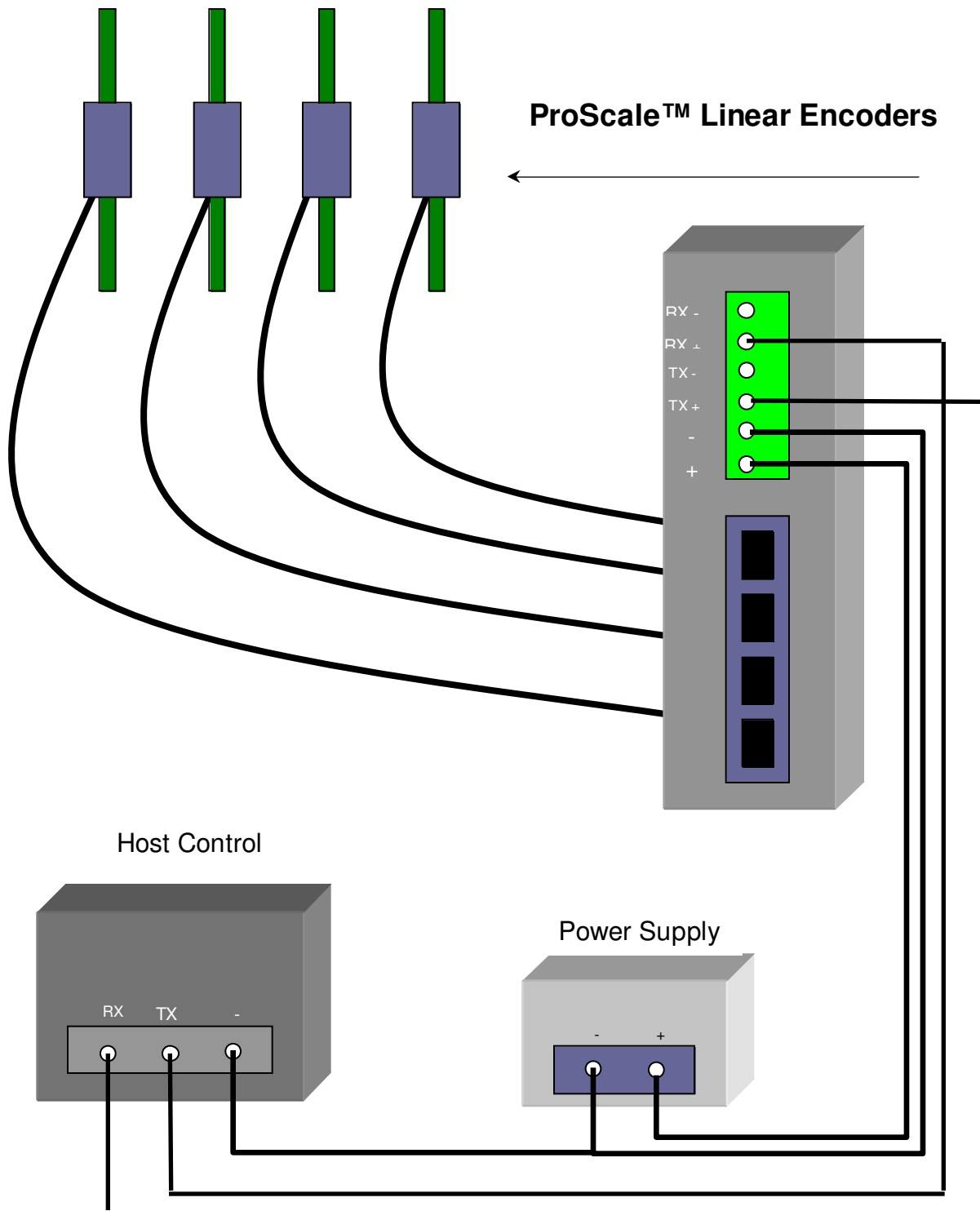

Typical RS422 ProMUX-8 Installation

This diagram illustrates multiple ProMUX-8 modules utilizing RS-422 communications. Note: ProScale encoders not shown for clarity, and ProMUX-8 shown with only 4 inputs.

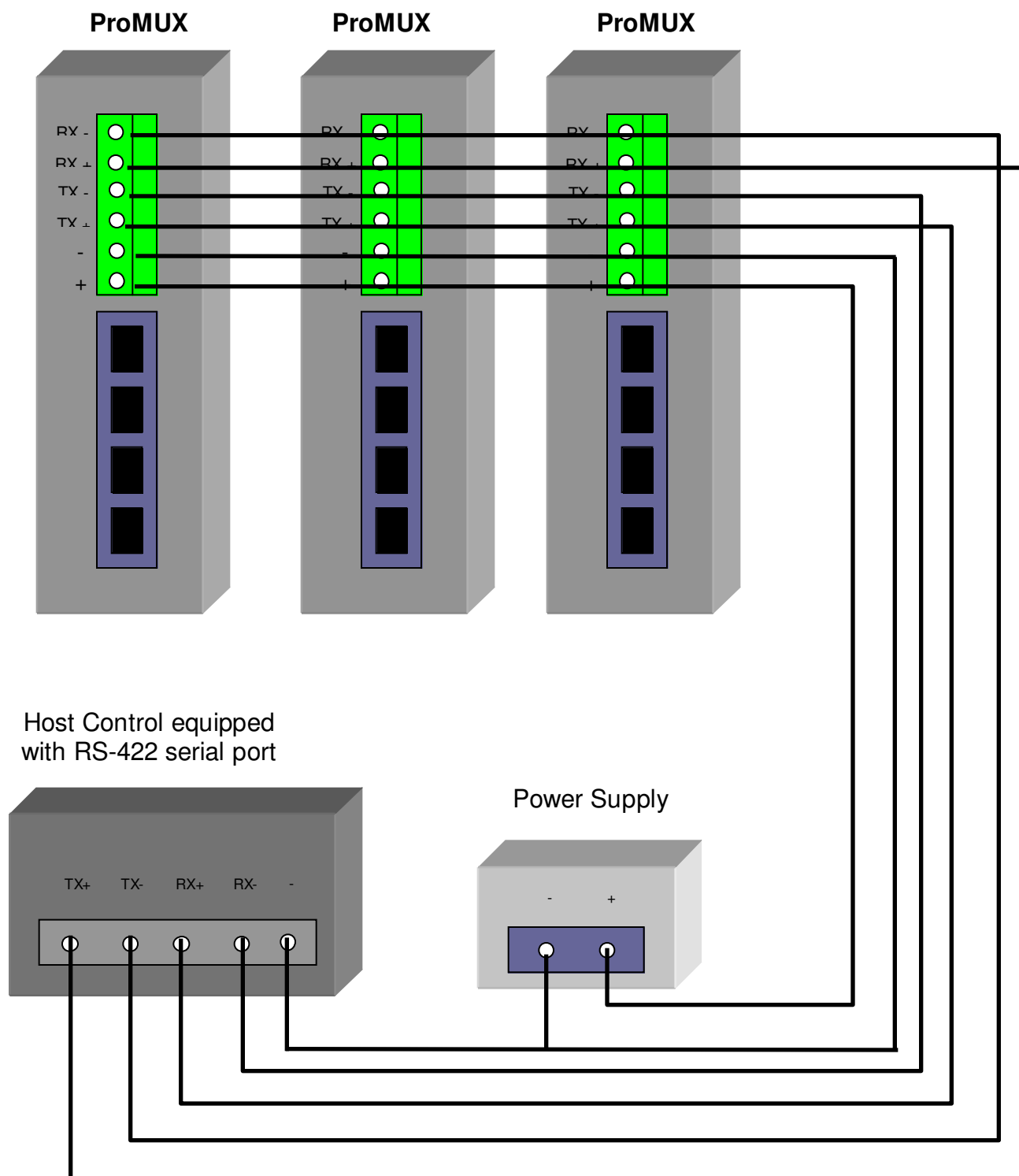

Communications Format

The communications format for the ProMUX-8 module is based on the standard ASCII character set although some data (bit fields) must be interpreted as binary data.

The serial port configuration uses an 8-bit word, no parity and one stop bit. No flow control.

Messages sent to and received from multiplexers utilize the data packet architecture. illustrated below.

Multiplexer ID	Command Letter	# of data bytes (n)	Data byte 1	Data	Data byte n
----------------	----------------	---------------------	-------------	------------	-------------

The command message format is as follows:

Byte 1 – Multiplexer ID digit (ASCII ‘1’ – ‘?’)

Byte 2 – Command Letter (See next section)

Byte 3 – Number of data bytes including checksum if enabled (ASCII ‘0’ – ‘~’)

Byte 4 to byte n – Data bytes (number anticipated by “Number of data bytes”)

Note: ID ‘0’ is reserved. See “Defaulting ProMUX-8 to Factory Settings”

ProMUX-8 modules act as slaves on the serial bus and thus cannot initiate communications. The PC or PLC host, acting as the bus master, must initiate all command communications. The ProMUX-8 will return the appropriate response packet.

Data Format

This document will refer to ASCII data using single quotation (‘) marks.

Example:

‘5’ = ASCII 5 = 35 Hex

‘P’ = ASCII P = 50 Hex

Note: To prevent control characters from being misinterpreted, the “number of data bytes” information will be offset by a value of 30h to reference a starting position of 30 hex, ‘0’ in the ASCII table. These instances will be noted.

Bit Fields – Some data transmitted or received uses all of the bits in the byte to represent data. As a result, an ASCII character cannot represent this data effectively. Data of this type will be noted.

Position Representation

The ProMUX-8 module can transmit positional data in three formats depending on the encoder being used.

- In the case of ProScale linear encoders, the data is represented in 100ths of millimeters (.01 mm).
- If using a ProScale SPC display, the ProMUX-8 will report the data to the host in the same units as being used by the ProScale display unit. This is either 100ths of millimeters (.01 mm) or 1000ths of inches (.001 in).
- If using an Accustar inclinometer, data is represented in 10ths of a degree. (.1 degree).

The ProMUX-8 can transmit data in either ASCII string format or in floating point binary mode. ASCII string format mode may be simpler to interface depending on the host and is easier to debug. The disadvantage is that it requires twice as much data to be sent to the host. Binary mode sends each encoder position data in 4 bytes instead of 8 but the data must be interpreted properly by the host.

ASCII String Position Format

The number of positional data bytes per encoder channel is constant at eight (including the sign and decimal point characters.)

For millimeters, the positional data format is $-xxxx.xx$ where the range of values can be -9999.99 millimeters to 9999.99 millimeters.

For inches, the positional data format is $-xxx.xxx$ where the range of values can be from -999.999 inches to 999.999 inches.

For degrees, the position data format is $-000xx.x$ where the range of value can be from -99.9 degrees to 99.9 degrees. In actuality, the Accustar sensor has a real world range of ± 60 degrees.

It is the responsibility of the host to determine the type of units being displayed based on the position of the decimal point within the data string and/or the encoder configuration status word (byte 5 of the position response packet).

Binary Position Format

When utilizing binary mode, position data is sent in 4 bytes instead of 8 and is represented in IEEE floating point format. If the host is PC based and utilizing C or C++, a **float** type pointer can be assigned to the location in the buffer holding the position information.

When using the floating point binary format, position data within the response data packet is located at the following positions:

Encoder 1	Bytes 7 – 10
Encoder 2	Bytes 11 – 14
Encoder 3	Bytes 15 – 18
Encoder 4	Bytes 19 – 22
Encoder 5	Bytes 23 – 26
Encoder 6	Bytes 27 – 30
Encoder 7	Bytes 31 – 34
Encoder 8	Bytes 35 – 38

Binary position data is sent least significant byte first.

Module Commands

Position Command (P)

Requests status and position data for all encoder channels.

Command (Host) example: *Request position data from module 1*

<u>Byte</u>	<u>Value</u>	<u>Description</u>
1	'1'	Module Address
2	'P'	Position command character
3	'0'	Number of data bytes to follow.

Position Response (ProMUX-8)

<u>Byte</u>	<u>Value</u>	<u>Description</u>
1	'1'	Echo of module address
2	'P'	Echo of command
3	's'	Number of bytes to be returned ((43h or 67d) + 30h offset)
4	0 – 255	Bit field representing the current status of the encoders B0 is encoder 1, B1 is encoder 2, etc. If bit is set, encoder is functioning properly.
5	0 – 255	Bit field representing type of encoder programmed for each channel. If bit is set, encoder type is ProScale. If bit is clear, encoder type is Accustar.
6	0 – 255	Bit field representing the multiplexer status B0 – Encoder Power Status --1 = OK, 0 = Fault B1 – 12 volt Power Status --1 = OK, 0 = Fault B2-B5 Future Use B6 – Binary Mode Status – 1 = Using Binary, 0 = ASCII B7 – Checksum Mode Status – 1 = Using Checksum
7	' ' or '-'	Sign data for encoder 1 (See format note 1 on next page)
8	'0' – '9'	Most significant byte for encoder 1 position data (See next page for position data format)
9	'0' – '9'	Next position data byte
10	'0' – '9'	Next position data byte
11	'0 – 9' or .	Next position data byte
12	'0 – 9' or .	Next position data byte
13	'0 – 9' or .	Next position data byte
14	'0'–'9'	Last position data byte
15 – 22		Data for Encoder 2, same as above
23 – 30		Data for Encoder 3
31 – 38		Data for Encoder 4
39 – 46		Data for Encoder 5
47 – 54		Data for Encoder 6
55 – 62		Data for Encoder 7
63 – 70		Data for Encoder 8

Scale Segment Adjustment Command (S)

The ProScale linear measurement encoder utilizes an absolute position technology based on a fixed measurement period. This period distance is approximately 430 mm in length. As a result, linear scales that have a length of less than or equal to 430 mm are completely absolute in resolving their position. This means that removing power from the system has no effect on calculating its current position when power is reapplied. Likewise, if the readhead is moved while power is disconnected, the correct absolute position will be determined when power is re-applied.

For scales that are longer than 430 mm, several *scale panels* (the actual measurement medium) are installed end-to-end on the aluminum scale extrusion. This results in effectively increasing the scale range by multiples of 430 mm. The disadvantage of this implementation is that although the readhead can calculate its absolute position on any individual scale panel, it does not know its position relative to the entire scale.

To accommodate this situation, the ProMUX-8 module “counts” the number of scale panels that have been traversed and multiplies this count by the scale period. The result is an accumulated absolute position. ProMUX-8 maintains this count in non-volatile memory such that the current position can be recalculated if power is cycled off and on.

A positioning error can occur if the readhead is moved from its current scale panel to a different scale panel while power is removed from the ProMUX-8 module. In this case, the accumulated absolute position will be in error by some multiple of 430 mm. To remedy this potential problem, ProMUX-8 supports a feature referred to as *Scale Segment Adjustment*. This allows the host to instruct the ProMUX-8 to increment or decrement its scale segment adjustment by one period each time this command is received.

Command (Host) Example: *Increment encoder channel 4 segment count on module 2.*

<u>Byte</u>	<u>Value</u>	<u>Description</u>
1	'2'	Address of ProMUX-8 module
2	'S'	Scale segment adjust command
3	'2'	Number of data bytes
4	'4'	Encoder channel to modify
5	'+'	'+' adds 430 mm, '-' subtracts 430 mm

Response (Acknowledge)

<u>Byte</u>	<u>Value</u>	<u>Description</u>
1	'2'	ProMUX-8 module address
2	'A'	A = Positive Acknowledge, N = Negative Acknowledge
3	'0'	Number of data bytes (none)

A positive acknowledge indicates that the command was received, decoded and executed correctly. A negative acknowledgement indicates that the command was not executed because of a data value problem. This could be an invalid encoder channel selection, an invalid mode byte, i.e. neither '+' or '-' or an invalid host command.

Multi-Segment Mode Command (L)

As described above, ProScale linear scales that are longer than 430 mm must interpret transitions from one scale panel to another. When *Multi-Segment Mode* is enabled, this is completed transparently to the host. In the special situation where a ProScale SPC display is being used with the ProMUX-8 module, the *Multi-Segment Mode* of operation must be disabled. This is because a similar segment transition algorithm is executing in the SPC display unit making its output appear to be one linear scale having n units of length.

For this reason, individual encoder channels can be selected to either enable or disable multi-segment mode. This is completed utilizing a bit field where a set bit enables the use of multi-segment mode and a clear bit defeats it.

Command Example: *Enable multi-segment mode on encoder channels 1 and 3 of ProMUX-8 module # 4*

<u>Byte</u>	<u>Value</u>	<u>Description</u>
1	'4'	Address of ProMUX-8 module
2	'L'	Multi-Segment Mode command
3	'1'	Number of data bytes
4	05h	Bits B0 and B2 are set in the bit field (NOT ASCII)

Response: *(Acknowledge)*

<u>Byte</u>	<u>Value</u>	<u>Description</u>
1	'4'	ProMUX-8 module address
2	'A'	A = Positive Acknowledge, N = Negative Acknowledge
3	'0'	Number of data bytes (none)

Enable Active Encoders Command (M)

Although a ProMUX-8 will support up to 8 encoders, the full compliment of inputs may not always be used. To indicate which ports are to be used on the ProMUX-8, the host can send a bit field representing the encoder channels that are to be made active.

If a bit is set, the appropriate encoder channel is enabled. B0 = channel 1, B1 = channel 2, etc.

Command Example: *Enable encoder channels 1 through 6 of ProMUX-8 module 3*

<u>Byte</u>	<u>Value</u>	<u>Description</u>
1	'3'	Address of ProMUX-8 module
2	'M'	Enable Encoder Command
3	'1'	Number of data bytes
4	3Fh	Bits B0, B1, B2, B3, B4, B5 are set in the bit field

Response (*Acknowledge*)

<u>Byte</u>	<u>Value</u>	<u>Description</u>
1	'3'	ProMUX-8 module address
2	'A'	A = Positive Acknowledge, N = Negative Acknowledge
3	'0'	Number of data bytes (none)

Encoder Types Command (E)

As stated earlier, the ProMUX-8 module can support either ProScale readheads or Lucas Accustar™ inclinometers. The ProMUX-8 must be instructed as to what type of encoder exists on each encoder channel.

A bit field is used to control this function. If a bit is set, the corresponding encoder channel is defined as ProScale type. If a bit is clear, the corresponding encoder channel is defined as Accustar type.

Command Example: *Encoder channels 1 and 2 are Accustar, the remainder are ProScale. The ProMUX-8 module is address 7.*

<u>Byte</u>	<u>Value</u>	<u>Description</u>
1	'7'	Address of ProMUX-8 module
2	'E'	Enable Encoder Command
3	'1'	Number of data bytes
4	FCh	Bits B0 and B1 are clear, the rest are set.

Response (*Acknowledge*)

<u>Byte</u>	<u>Value</u>	<u>Description</u>
1	'7'	ProMUX-8 module address
2	'A'	A = Positive Acknowledge, N = Negative Acknowledge
3	'0'	Number of data bytes (none)

Inter-Command Delay (I)

When multiple ProMUX-8 units are used on a common RS-422 communications bus, each utilizes an inter-command packet delay timer. This timer prevents information contained within a data packet that is being sent to one ProMUX-8 unit from being misinterpreted by another ProMUX-8 unit as a valid device address.

When the address byte of a data packet is transmitted from the host to all ProMUX-8 units on the bus, all units hear the address byte. The specified ProMUX-8 unit continues to receive and process data from the packet while all other units ignore the remainder of the data packet. This “sleep” process continues until the host’s transmit side of the bus becomes idle for a specific amount of time. This command defines the amount of idle time that must pass before other units on the bus will again begin listening for new commands.

The units of time are in milliseconds with a minimum time setting of 2 milliseconds and a maximum of 9,999 milliseconds (9.999 seconds). The default setting is 3000 milliseconds (3 seconds).

Command Example: *Set ProMUX-8 with address 6 to a 258 ms delay.*

<u>Byte</u>	<u>Value</u>	<u>Description</u>
1	‘6’	Address of ProMUX-8 module
2	‘I’	Inter-Command Delay Command
3	‘4’	Number of data bytes to follow
4	‘0’	Thousands of milliseconds
5	‘2’	Hundreds of milliseconds
6	‘5’	Tens of milliseconds
7	‘8’	milliseconds

Response (*Acknowledge*)

<u>Byte</u>	<u>Value</u>	<u>Description</u>
1	‘6’	ProMUX-8 module address
2	‘A’	A = Positive Acknowledge, N = Negative Acknowledge
3	‘0’	Number of data bytes (none)

Note: Data for this command MUST ALWAYS contain 4 characters. As in the example above, a leading ‘0’ was used for the thousands digit. If a 15 millisecond delay was needed, the data would be “0015”.

If any of the four data characters are sent outside the range of ‘0’ to ‘9’, the ProMUX-8 will return a negative acknowledgement (NAK). If a value of less than two milliseconds is sent, ProMUX-8 will automatically be configured to 2 milliseconds.

Position Transmit Mode Command (F)

As previously stated, the ProMUX-8 can transmit position data in either ASCII string mode or floating point binary mode. The position transmit mode is configured using this command.

Command Example: *Enables the ProMUX-8 to transmit position data in floating point binary mode*

<u>Byte</u>	<u>Value</u>	<u>Description</u>
1	'1'	Address of ProMUX-8 module
2	'F'	Binary Mode Command
3	'1'	Number of data bytes
4	'1'	Enables binary mode

Response (*Acknowledge*)

<u>Byte</u>	<u>Value</u>	<u>Description</u>
1	'1'	ProMUX-8 module address
2	'A'	A = Positive Acknowledge, N = Negative Acknowledge
3	'0'	Number of data bytes (none)

To disable binary mode, issue the same command with data byte 3 equal to '0'.

Checksum Operation Command (C)

ProMUX-8 can be configured to transmit and receive a 16-bit checksum appended to the end of every command and response packet. This feature enhances the data integrity of data packet transmission between the host control and the ProMUX-8 modules on the communication bus.

The checksum is calculated by summing all of the data in the command or response packet. This 16-bit value is appended to the end of the packet in two 8-bit words. The checksum value is transmitted with least significant byte first.

$$16 \text{ bit } \Sigma = \text{packet byte } 1 + \text{packet byte } 2 + \dots \text{ packet byte } n$$

Command Example: *Enables the ProMUX-8 to transmit/receive data with 16-bit checksum appended to command/response packet.*

<u>Byte</u>	<u>Value</u>	<u>Description</u>
1	'1'	Address of ProMUX-8 module
2	'C'	Checksum Command
3	'1'	Number of data bytes **
4	'1'	Enables checksum mode

Response: *(Acknowledge)*

<u>Byte</u>	<u>Value</u>	<u>Description</u>
1	'1'	ProMUX-8 module address
2	'A'	A = Positive Acknowledge, N = Negative Acknowledge
3	'2'	Number of data bytes (checksum)
4	A4h	Checksum low byte
5	00h	Checksum high byte

** Note that when switching from non-checksum mode to checksum mode, the command packet will NOT include a checksum but the response packet will. The inverse is true when switching from checksum mode to non-checksum mode.

When checksum operation is enabled, all command and response packets will be an additional 2 bytes in length and thus the packet's "bytes to send" field (byte 3) will be incremented by a value of 2.

Command Transmission Notes

ProMUX-8 utilizes a software timer to monitor the elapsed time between bytes in a command packet transmitted from the host. This time limit is 3 seconds. If the time between byte transmissions of a packet exceeds this limit, ProMUX-8 resets its communication command parser. This facility prevents ProMUX-8 from “hanging” when a command packet is interrupted or fails to be completely sent.

ProMUX-8 will transmit a “negative acknowledgment” (‘N’ response) if any of the following events occur:

- An invalid command is sent.
- A valid command is sent with an invalid data parameter (if applicable).
- A command packet with an invalid checksum (if enabled).

Note that when checksum mode is enabled, the checksum bytes must also be sent within the 3-second time limit. When using checksum mode, ProMUX-8 will not respond until a complete packet is received *including the two checksum bytes*.

Jumper Settings

Although the ProMUX-8 utilizes EEPROM to maintain specific non-volatile data, some jumpers exist on the printed circuit board to set the hardware for various configurations.

Serial Interface Physical Layer Setting

ProMUX-8 can communicate to the host via either RS-232 or RS-422. The operating mode is selected via jumpers JP12, JP13 and JP14.

To use RS-232, move the shunts on jumpers JP12, JP13 and JP14 to pins 2 and 3.

To use RS-422, move the shunts on jumpers JP12, JP13 and JP14 to pins 1 and 2.

Baud Rate Setting

The ProMUX-8 can support 4 different baud rates configured by jumper setting.

9600	Jump 9 Closed	Jump 10 Closed
19200	Jump 9 Open	Jump 10 Closed
57600	Jump 9 Closed	Jump 10 Open
115200	Jump 9 Open	Jump 10 Open

Lucas Accustar Support

ProMUX-8 supports Lucas Accustar® angular position encoders. These encoders connect to the ProMUX-8 using a 6 pin modular connector similar to the ProScale encoders. Jumpers JP1 – JP8 correspond to inputs 1 through 8. The appropriate jumper is closed (shorted) when an Accustar angular encoder is being used on the corresponding ProMUX-8 input. In addition, the encoder type control register must be set to indicate that the encoder is an Accustar type. See **Encoder Types** for details about this setting.

Self-Test

Upon application of power, the ProMUX-8 will check EEPROM and sequence the LEDs. After this power up procedure, normal operation will begin with active encoders causing the corresponding LEDs to illuminate.

Address Setting

The ProMUX-8 unit utilizes a rotary switch to set the device address. Current versions of the ProMUX-8 only support addresses 1 through 15. Address 0 is reserved. See “Defaulting ProMUX-8 to factory settings”. NOTE: Each ProMUX-8 on the system must be configured with a unique address. If more than one unit has the same address, data collisions will occur on the data bus and received data will be invalid.

Defaulting to Factory Settings

ProMUX-8 incorporates a non-volatile memory system utilizing EEPROM. This allows device parameters to be stored without the need for continuous power being connected to the unit or battery back-up.

Under certain circumstances, it may be desirable to restore the ProMUX-8 configuration parameters back to factory defaults. To default the ProMUX-8 to factory settings, complete the following:

1. Remove power from the ProMUX-8 module.
2. Set the address switch to 0.
3. Apply power to the unit. After the initial self-test sequence, all of the LEDs will blink on and off. This indicates that the memory defaulting process is complete.
4. Remove power from the unit
5. Reset the address switch to the desired address (other than 0).
6. Re-apply power.

The EEPROM incorporated into the ProMUX-8 is rated for greater than 1 million erase/write cycles and infinite read cycles. Data retention is rated for greater than 200 years.

Network Connections

As illustrated on pages 17 and 18, the ProMUX-8 can be connected for either RS-232 or RS-422 operation.

When utilizing RS-232 mode, the ProMUX-8 can be connected directly to a computer's serial port without the need for additional adaptors. External power is required to operate the unit. (NOTE: JP12, 13, 14 must be set on pins 2 and 3.) **RS-232 mode only supports ONE ProMUX-8 on the data bus. For multiple ProMUX-8 units on a common bus, RS-422 mode must be used.**

RS-232 Connections

ProMUX-8	Computer Port (DB9 pin)
Terminal 1 – (External power 14-24VDC)	N/A
Terminal 2 – (External power/Data ground)	Pin 5
Terminal 3 – Transmit +	Pin 2
Terminal 4 – Transmit -	N/A
Terminal 5 – Receive +	Pin 3
Terminal 6 – Receive -	N/A

RS-422 mode is used when multiple ProMUX-8 units are to be attached to a common data bus. To communicate with a standard PC, a RS-232/RS-422 adapter must be purchased and installed. JP12, 13, and 14 must be set on pins 1 and 2.

RS-422 Connections

ProMUX-8	RS-232/RS-422 Converter
Terminal 1 – (External Power 14-24 VDC)	N/A
Terminal 2 – (External Power/Data Ground)	Converter Ground
Terminal 3 – Transmit +	RS-422 Receive +
Terminal 4 – Transmit -	RS-422 Receive –
Terminal 5 – Receive +	RS-422 Transmit +
Terminal 6 – Receive -	RS-422 Transmit –

Power Panel Connections

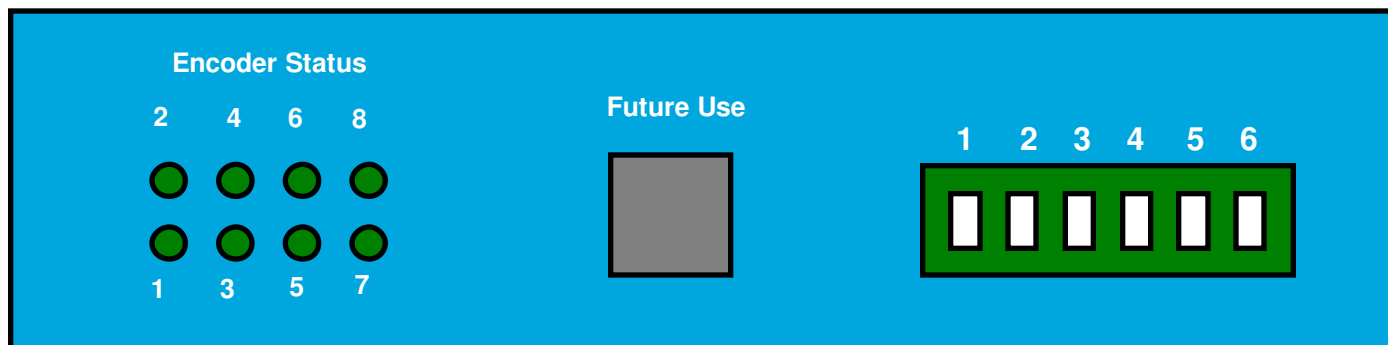

- Terminal 1 – Power 14-24VDC
- Terminal 2 – Power / Data ground
- Terminal 3 – Transmit +
- Terminal 4 – Transmit -
- Terminal 5 – Receive +
- Terminal 6 – Receive -

Encoder Panel Connections

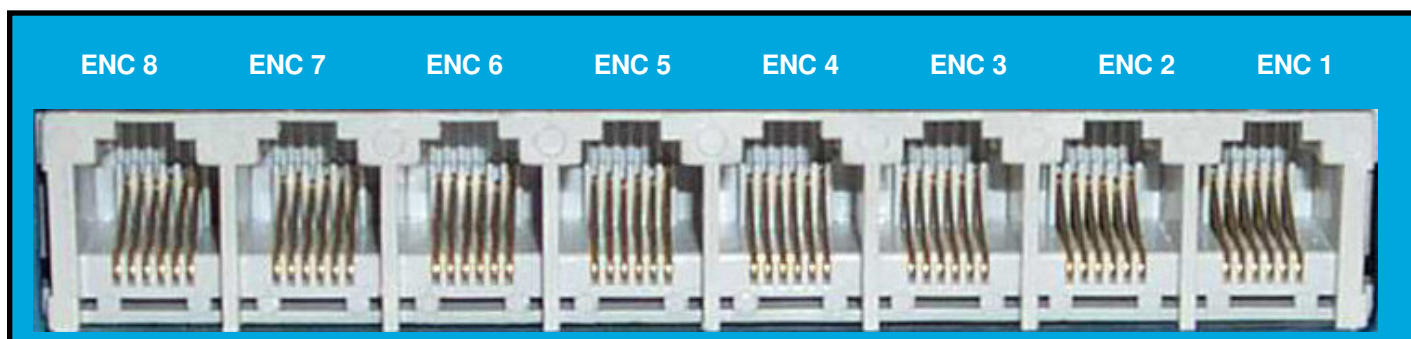

General Description

The Analog Interface Unit or AIU is an interface device that provides the user of a ProScale digital measurement system with a method of generating an analog DC output voltage that is proportional to the currently displayed ProScale measurement system position. This output can be used as an A/D converter input on a PLC or other device that utilizes an analog input signal.

Basic Theory of Operation

The AIU converts the digital position signal from the ProScale display and compares it to an internal pre-programmed set of lower and upper position limits. The AIU uses a ratio utilizing these factors and generates an analog output via a 12-bit digital-to-analog converter. This provides 4096 discrete voltage steps over the defined measurement range.

Terminal Block Connections

- Terminal 1 – Positive 7 to 24 VDC supply voltage
- Terminal 2 – Ground
- Terminal 3 – Analog output
- Terminal 4 – Ground
- Terminal 5 – Programmable output, active LOW
(encoder failure or display SEND button)

Mounting

The AIU is mounted via a standard 35 mm wide DIN rail. This can be either 7.55 mm or 15 mm height. A quick release latch can be disengaged using a small flat screwdriver and pulling on the latch tab located on the bottom of the AIU housing.

Connections

1. Connect a 7 to 24 volt DC power supply to terminals 1 and 2. Terminal 1 is positive. Ground terminal 2 must share a common ground with that of the PLC. **DO NOT APPLY POWER UNTIL ALL CONNECTIONS HAVE BEEN COMPLETED.**
2. Connect the analog output on terminals 3 and 4 to the analog input of the PLC or other control device. Terminal 3 is positive.
3. Optionally, connect the programmable output on terminal 5 to a digital input of the PLC or control device.
4. Connect the SPC cable between the ProScale display and the AIU. The cable connectors are keyed for one direction. Do not force the connectors in the wrong direction.
5. Remove the snap-on cover from the AIU by squeezing the sides of the top cover and set the analog output configuration jumper JP1 to pins 1-2 for 0-10 volts output or pins 2-3 for 0-5 volts output.
6. Optionally, install a jumper on JP2 for a supply voltage pull-up if needed. If JP2 is left open, the AIU will provide a ground signal when an encoder fault/SEND button is active. When normal, the output is high impedance. If a jumper is installed on JP2, the normal output will be pulled up to the supply voltage via a 10K ohm resistor.
7. Apply power to the AIU. The two indicators should momentarily light up to indicate operation. If the ProScale display is connected properly, the *status* LED will illuminate.

Calibration and Position Limit Setting

Complete the following procedure to calibrate the ProScale and the AIU for position measurement.

1. Set the position offset of the ProScale display using the PLUS, ZERO and MINUS buttons. See the ProScale user's manual for additional information regarding this procedure.
2. Move the readhead on the scale to the point that will be the minimum position of travel. Press the Lower Limit pushbutton on the AIU. The limit switch *activation* LED will momentarily illuminate.
3. Move the readhead on the scale to the point that will be the maximum position of travel. Press the Upper Limit pushbutton on the AIU. The limit switch *activation* LED will momentarily illuminate.

The AIU is now calibrated with the ProScale display. When the displayed position is at or below the programmed lower limit, the analog output will be at approximately 0 VDC (typically about 3-4 millivolts.) When the displayed position is at or above the programmed upper limit, the analog output will be at either 5 VDC or 10 VDC depending on the setting of jumper JP1. Displayed positions between the lower and upper limits will generate an analog output proportional to distance from the current position and the lower limit.

NOTE: If the offset of the ProScale display is reconfigured, the AIU's upper and lower limits must also be reconfigured. Failure to do so will result in unexpected analog output from the AIU.

Determining the Voltage Per Step Output

As stated earlier, a 12-bit digital-to-analog converter generates the analog output of the AIU. This yields 4096 discrete steps for the position range of the AIU.

To calculate the linear distance per step, divide the range of motion of the ProScale by 4096. An example follows:

Lowest position of motion: 1.500 inches
Highest position of motion: 7.750 inches
Range of motion: 6.250 inches
Distance per step: $6.250 \div 4096 = .00152$ inches per step.

Next, determine the voltage per step of the AIU. This depends on the analog output voltage range setting of JP1.

JP1 1-2 10 volt range = .00244 volts per step.

JP1 2-3 5 volt range = .00122 volts per step.

If the AIU were generating an analog output of 2.999 volts with the voltage range set to 10 volts, the calculated position of the ProScale would be:

$2.999 \text{ volts} / .00244 \text{ volts per step} = 1229 \text{ steps (rounded)}$.

$1229 \text{ steps} \times .00152 \text{ Inches per step} = 1.868 \text{ inches}$.

Current position: $1.500 \text{ inches} + 1.868 \text{ inches} = 3.368 \text{ inches}$.

Note that rounding error can have an effect on the resulting calculations. The actual calculated position should have been 3.374 inches if rounding had not been used. The error is .17%

Considerations in A/D Conversions

The resolution of the A/D converter being used by the PLC or control device will have a direct impact on the measurement and conversion capabilities of the system.

In the previous example, the voltage per step was calculated using the 12-bit resolution capability of the AIU. If the PLC or control device utilizes an A/D converter with a different resolution, then that resolution must be used.

As an example, if the PLC's A/D converter resolution was only 10-bit, then the voltage per step would be:

$10 \text{ volt range} / 1024 = .00976 \text{ volts per step}$

$5 \text{ volt range} / 1024 = .00488 \text{ volts per step}$

This results in less resolution capability and thus less position accuracy capability when calculating the ProScale's position. In summation, the resolution of the PLC's A/D converter should be at least 12-bit or higher to provide maximum conversion accuracy.

Programmable Output

The AIU has a programmable output that can be used for either an encoder fault output or an output that activates when the SEND key is pressed on the ProScale display.

When configured for encoder fault, the output of the AIU will go low (ground) when the SPC digital signal from the display is interrupted.

When configured for the display SEND button, the output will go low for approximately 100 milliseconds when the SEND button is depressed on the ProScale display. This can be useful in signaling the PLC when a measurement sample is to be completed and/or recorded.

The unit can be configured for either mode by the following:

Encoder Fault output – Remove power from the AIU. Press and hold the UPPER LIMIT switch while applying power to the AIU.

Display SEND Button - Remove power from the AIU. Press and hold the LOWER LIMIT switch while applying power to the AIU.

Re-establishing Factory Defaults

The AIU has the option of restoring factory default values in non-volatile memory if necessary. To activate this feature, complete the following:

1. Remove power from the AIU.
2. Depress and hold **both** the UPPER and LOWER limit switches while applying power.
3. Release the limit switches.

Factory Default Values

Lower Position Limit – 0.000 inches

Upper Position Limit – 4.000 inches

Programmable Output Function – Encoder Failure

Powering the ProScale

The user may power the ProScale display directly from the AIU via the SPC cable without the use of batteries in the display.

To enable this feature, move the jumper JP2 inside the ProScale display to the **5-24 VDC** setting.

Note: This feature is available only when using the ProScale *General Purpose* display. The feature cannot be implemented when an incremental readhead is being used.

PRODUCT REGISTRATION

Fill out for your records **and**
FAX to Accurate Technology @ +1.828.654.8824 or
Register on line at <http://www.proscale.com/registration.htm>

Name _____

E-Mail _____

Company _____

Address _____

Address _____

City _____

State/Region _____

Zip/Postal Code _____

Country _____

Purchased From: _____

Purchased When: _____

Serial Number:

**Thank you for choosing an
Accurate Technology Product**



MADE IN USA

Accurate Technology, Inc.

270 Rutledge Rd. Unit E

Fletcher, NC 28732 USA

800 233-0580 • 828-654-7920

Fax 828-654-8824

www.proscale.com

customerservice@accurate-technology.com

This manual is available at www.proscale.com

*Please return your Product Registration Card
or register your system at:*

<http://www.proscale.com/registration.htm>

P/N 800-1098-001, Revision A, Copyright © 2003, Accurate Technology, Inc. All rights reserved