

# Accurate

TECHNOLOGY INC.

*Linear Digital Measuring Systems*

## ProStop™



### **ProStop Models 4, 8, 10, 20**

*Applies to ProStop products using firmware version 3.xx only.*

**INSTALLATION**

---

# WARRANTY

Accurate Technology, Inc., warrants the ProStop system against defective parts and workmanship for 1 year commencing from the date of original purchase. Upon notification of a defect, Accurate Technology, Inc., shall have the option to repair or replace any defective part. Such services shall be the customer's sole and exclusive remedy. Expenses incidental to repair, maintenance, or replacement under warranty, including those for labor and material, shall be borne by Accurate Technology, Inc. (Including freight or transportation charges during the first 30 days).

Except as expressly provided in this warranty, Accurate Technology, Inc., does not make any warranties with respect to the product, either expressed or implied, including implied warranties of merchantability or fitness for a particular purpose, except as expressly provided in this agreement.

Accurate Technology, Inc., shall not be liable for any special, incidental, or consequential damages or for loss, damage or expense directly or indirectly arising from the customer's use of or inability to use the equipment either separately or in combination with other equipment, or for personal injury or loss or destruction of other property, or from any other cause.

To request repair work (either warranty qualified parts or not), contact Accurate Technology, Inc. directly by phone, fax, or e-mail. A Returned Merchandise Authorization (RMA) number is required before returning a product for repair.

## Accurate Technology, Inc.

+1 828.654.7920

[www.proscale.com](http://www.proscale.com)

800.233.0580

828.654.8824 (F)

[info@accurate-technology.com](mailto:info@accurate-technology.com)

## **SAFETY WARNING**

**Before installing ProScale on any machinery:  
Turn off machine and disconnect power.**

## **SAFETY WARNING**

---

# Table of Contents

<b>SECTION 1</b>	<b>GENERAL INFORMATION</b> .....	<b>4</b>
INTRODUCTION.....		4
ABOUT THIS INSTALLATION MANUAL .....		4
PROSTOP SPECIFICATIONS .....		5
ABOUT PROSTOP.....		6
<i>Scales</i> .....		6
<i>Encoders</i> .....		6
<i>Digital Readouts</i> .....		7
Surface Mount General Purpose LCD .....		7
Surface Mount BASIC LCD.....		7
Compact Surface Mount LCD .....		7
<i>Quick Set Assemblies</i> .....		7
<b>SECTION 2</b>	<b>INSTALLATION</b> .....	<b>8</b>
ASSEMBLY .....		8
MOUNTING TO YOUR TABLE .....		9
CALIBRATION.....		9
READOUT OPERATION.....		9
STOP OPERATION .....		10
MAINTENANCE.....		10
FREQUENTLY ASKED QUESTIONS .....		10
<b>SECTION 3</b>	<b>ACCESSORIES</b> .....	<b>11</b>
PRORF SPC.....		11
SPC CONVERTER .....		11

## Introduction

ProStop is a general purpose Digital Stop & Fence System. It is ideal for use on Miter saws, Chop Saws, Radial Arm Saws or any other application where a moveable stop along a fixed back fence is desired. It has been designed using high quality extruded aluminum and machined parts to provide the best accuracy and repeatability.

The core technology of the ProStop is a ProScale™ Measuring System. ProScale measuring systems are affordable precision electronic devices for making linear measurements with speed and accuracy. ProScale consists of a SCALE, an ENCODER (also called a readhead) and a Digital Readout (DRO). ProStop uses Inductive measurement technology, the same technology used in newer high-quality digital calipers.

## About This Installation Manual

- **This manual includes specifications and INSTALLATION information for ProStop products**
- **This manual **DOES NOT** include OPERATION information for the Digital Readout. Operating and programming information can be found in the Digital Readout OPERATION manual.**

---

# ProStop Specifications

Measuring Range*:	50, 94, 118, and 238 inches (1.3, 2.4, 3.0, and 6.0 meters)
Accuracy:	+/- 0.010 inches (+/- 0.25 mm)
Resolution	Decimal Inch Mode: 0.001 inches Fraction Inch Mode: 1/64 Decimal Metric Mode: 0.01 mm
Repeatability:	Decimal Inch Mode: 0.001 inches Fraction Inch Mode: 1/64 Decimal Metric Mode: 0.01 mm
Operating Temp:	32 to 120°F (0 to 50°C)
Slew Rate:	60 inches/sec (1500mm/sec)
Output Format:	See Digital Readout Operation Manual
Encoder:	12 inch (300mm) six-conductor cable terminated by RJ12
Dimensions:	Available at <a href="http://www.proscale.com">www.proscale.com</a>
Warranty	One year from date of purchase
Battery Life	8-12 months

## All ProStop products are **MADE IN USA**

**\*MEASUREMENT range is approximately 6 inches *shorter* than the PHYSICAL length of the aluminum fence extrusion.**

---

## About ProStop

All ProStop systems consist of a **SCALE** (or track), an **ENCODER**, (or readhead) a **DIGITAL READOUT** (DRO), a fence extrusion, a sliding stop, and two Quick Set assemblies.

The **SCALE** consists of a series of conductive patterns bonded to an aluminum extrusion. The scale used for ProStop is the same scale used for the Model 280 products.

The **ENCODER** contains a computer chip which transmits and receives signals to and from the **SCALE** using inductive coupling. The received signal is used by the encoder to calculate its position to within 10 microns (10 $\mu$ m or .0004in). This position data is then sent to the **DIGITAL READOUT**, where it can be displayed in millimeters, centimeters, inches, or fractions and sent to an external data acquisition device via the DRO output.

Multiple **ENCODERS** (connected to individual **DIGITAL READOUTS** or data acquisition units) can be used on the same **SCALE** simultaneously.

## Scales

ProStop systems use Inductive Incremental technology. The Scales have a repeating “bar” pattern on a colored laminate.



These systems measure position by reading a pattern and determining how far the encoder has traveled. Removing power from these systems will necessitate re-calibration. (Recalibration can be as easy as pressing a key on the front panel of the DRO if the DATUM feature of the readout was set-up when installed. See the DRO Operation Manual for details.)

To shorten these scales simply cut to the desired length.

## Encoders

Encoders for ProStop have black housings.. The Encoder orientation on the scale can be reversed without adverse affect to operation (the reading direction will also reverse). These Encoders are supplied with a 12 inch (300mm) cable. Custom length cables are available up to 20 feet (6m).



---

## Digital Readouts

ProStop measuring Systems can operate with several different Digital Readouts, but are supplied with a General Purpose readout unless otherwise specified. Refer to the OPERATION manual that accompanied your **DIGITAL READOUT** for information about programming, installation and operation.

Below are brief descriptions of the Digital Readouts available for your ProStop System.

### Surface Mount General Purpose LCD

This is the standard readout for ProStop. It is powered by two AA alkaline batteries from the factory. It can also be powered by 24VDC. The built-in SPC output port can be used for positioning monitoring or data collection. Additionally, an output can be configured to alert the operator when the stop drifts out of position, or if an upper or lower limit is exceeded. Extensive programming options allow the readout to be customized to suit an exact application.



### Surface Mount BASIC LCD

This is an optional readout for ProStop. It is powered by two AA batteries. Its keypad only allows operators to change units and the position calibration (both of these can also be locked out using the readout's programming options).



### Compact Surface Mount LCD

This is an optional readout for ProStop. It is powered by one lithium battery. Its keypad only allows operators to change units and the position calibration (both of these can also be locked out using the readout's programming options).



## Quick Set Assemblies

Two Quick Set Assemblies are included with every ProStop shipment. These are useful for shops that have one or two positions (cut sizes) that are very common and used often. After ProStop is installed and calibrated, the Quick Sets can be installed into the fence, allowing very fast and precise setup for the most common cut sizes.



NOTE: These are designed for re-positioning the stop only. They are not intended to be used as an additional stop.

ProStop is easy to install. By following the basics of good installation, error-free operation can be expected. ProStop can be installed on many different types and brands of equipment, so all installations will be different. Therefore, it's the responsibility of the installer to choose the bolts, screws, or other mounting hardware that guarantee proper installation for optimum operation.

### Assembly

Each ProStop ships from Accurate Technology in two packages. The first contains the linear scale and fence extrusion. The second package contains the remaining components. These parts should be assembled prior to mounting the ProStop.

1. Carefully slide the encoder onto the scale.
2. Stop Installation: Loosen the lock handle and slide the stop onto the fence extrusion, guiding the lock nut into the upper slot on the fence extrusion.
3. Slide the encoder under the Guide Clip. The post on the top of the encoder should snap into the recess in the Guide Clip.
4. Plug the encoder into the DRO.
5. Move the stop assembly left to right and note if the DRO readings increase or decrease. Depending upon the installation, it may be necessary to program the DRO to reverse the reading direction.  
(Refer to the Operation Manual that accompanied the digital readout for more information).
6. To install the 45/90 stop plate:
  - a. Remove the round spacer from the bottom of the flip stop assembly.
  - b. Slide the 45/90 plate into place on the flip stop assembly and tighten the supplied installation bolts. (The plate can be installed with the 45 or 90 degree edge facing the saw, depending on your application.)

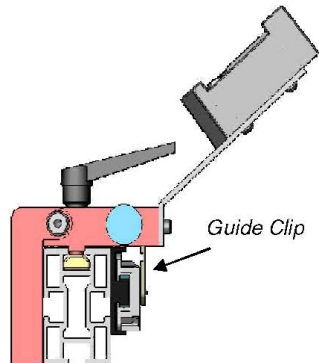

---

## Mounting to your Table

1. Position ProStop on the tabletop where desired.
2. Mark a line onto the table top, along the front edge of the fence.
3. Temporarily remove the ProStop assembly.
4. Make a second line mark 7/8 inch (22mm) behind the first line. (This line corresponds to the centerline of the fence extrusion.)
5. Drill holes into the tabletop on the second line. The holes should be drilled as far apart as possible, to ensure a rigid installation.
6. Insert the supplied 3/8" bolts through the table from the bottom side. Install the supplied Heavy Hex Nut onto the bolt – install one thread deep only at this time.
7. Slide the ProStop fence back into place, capturing the Hex Nuts in the bottom T-slot. After the ProStop is in place and aligned to the saw, tighten all bolts.

## Calibration

Once installed, ProStop can be calibrated easily and quickly. Following is an example of calibrating ProStop for a cutoff saw application. Other installations follow the same general procedure.

1. Check to be sure installation of all parts is complete, all fasteners are secure and the Encoder is plugged into the DRO.
2. Cut a part using your normal operation.
3. Measure the length of the part with the most precise measuring tool available (i.e. digital calipers).
4. Press the zero key on the DRO.
5. Press and hold the PLUS key on the DRO to scroll until the measurement is displayed. (The longer the PLUS key is held down, the faster the reading will scroll.)
6. When the proper reading is reached, lock the DRO. This prevents accidental loss of calibration. (Refer to the Readout Operation manual for more information about locking.)
7. Re-calibrate if necessary after changing saw blade.

## Readout Operation

**MANY** features of the digital readout can be customized to suit your application. Refer to the Readout Operation Manual for details.

---

## Stop Operation

1. Flip the stop down.
2. Unlock the stop by turning the lock handle(s) 180 degrees counterclockwise.
3. Slide the stop into the desired position. If using the fine adjustment option:
  - a. Slide the stop to the approximate position.
  - b. Turn the lock handle on the fine adjustment block until it is locked.
  - c. Turn the fine adjust knob to position the stop. (Each full turn is 0.050 inches.)
4. Turn the lock handle on the stop block until it is locked.
5. Make necessary cuts.
6. When not in use, the stop can be flipped up to allow for rough cutting.
7. If you have a cut size that is used very often, install a Quick Set assembly into the front T-slot of the fence extrusion, and tighten its set screw. The Quick Set can now be used to bring the sliding stop back to a known position very quickly.



## Maintenance

The fence extrusion should be cleaned of all debris often. The DRO should be cleaned periodically with compressed air to remove any dust on the lens and keys. All fasteners should occasionally be checked for tightness.

## Frequently Asked Questions

### What does no Enc mean?

If the Encoder is off the Scale, or the Encoder cable is unplugged from the Digital Readout, **no Enc** will appear on the LCD. To clear:

1. Be sure the Encoder is on the Scale.
2. Unplug the Encoder from the Digital Readout for one second and then reconnect the Encoder.
3. Connect the Encoder to the Digital Readout.

### The Digital Readout does not change, or changes very little, as the Scale or Encoder moves.

1. The Digital Readout is in the HOLD mode.
2. The Encoder is not moving with the stop properly.
3. A linear scaling factor is set very low in the digital readout.

### ProRF SPC

ProRF allows linear measurement or position data to be transmitted wirelessly to a PC or other device having a USB or RS232 connection. The system uses 802.15.4 radio modules to provide reliable two way communication. The transmitter plugs into any Digital Readout with an SPC output.



### SPC Converter

Gageway SM™ converts SPC output from many of our digital readouts to serial or USB data.



---

**Thank you for choosing a ProScale Product**



**MADE IN USA**

**Accurate Technology, Inc.**

270 Rutledge Rd. Unit E

Fletcher, NC 28732 USA

800 233-0580 • 828-654-7920

Fax 828-654-8824

[www.proscale.com](http://www.proscale.com)

[customerservice@proscale.com](mailto:customerservice@proscale.com)

*This manual is available at [www.proscale.com](http://www.proscale.com)*

*Please register your system at:  
[www.proscale.com/registration.htm](http://www.proscale.com/registration.htm)*

**Part # 800-1080-100**

**Copyright © 2008, Accurate Technology, Inc. All rights reserved.**